

Compensation for the Landing Impact Force of a Humanoid Robot by Time Domain Passivity Approach

Yong-Duk Kim*, Bum-Joo Lee*, Jeong-Ki Yoo*, Jong-Hwan Kim*, and Jee-Hwan Ryu†

*Robot Intelligence Technology Laboratory, Dept. of EECS, KAIST,
Guseong-dong, Yuseong-gu, Daejeon, 305-701, Republic of Korea
Email: {ydkim,bjlee,jkyoo,johkim}@rit.kaist.ac.kr

†School of Mechanical Engineering, Korea University of Technology and Education,
Cheonan-city, 330-708, Republic of Korea
Email: jhryu@kut.ac.kr

Abstract— In this paper, a method to reduce the landing impact force is proposed for a stable dynamic walking of a humanoid robot. To measure the meaningful landing impact force, a novel foot mechanism, which uses FSRs (Force Sensing Resistors), is introduced as well. Humanoid robot might become unstable during the walking due to the impulsive contact force from the sudden landing of its foot. Therefore a new control method to decrease the landing impact force has been required. In this paper, time domain passivity control approach is applied for this purpose. Ground and the foot of the robot are modeled as two one-port network systems which are connected and exchanging energy each other. And, the time domain passivity controller which has the landing impact force as input and foot's position to trim off the force as output, is implemented. Unlike previous works, the proposed controller can guarantee the stability of the robot system without any dynamic model information at all. The small sized humanoid robot, HanSaRam-VI which has 25 DOFs, with the proposed foot mechanism is developed to verify the proposed approach through dynamic walking experiments.

I. INTRODUCTION

A humanoid robot is a bipedal (i.e., two-legged) intelligent robot, and is expected to eventually evolve into one with a human-like body. Recently, many researches have been focused on a development of humanoid robot which is similar to human beings. Honda R&D's humanoid robots [1], WABIAN of Waseda University [2], H6 [3], and HanSaRam [4] are well known humanoid robots. Humanoid robots have been developed to resemble human beings, both morphologically and functionally.

Current research being conducted in collaborating operations with human beings [5][6], has progressed far beyond studies in walking pattern generation [7][8] and an online (real-time) balance control [9][10] during walking. But the standard and most important function of the humanoid robot is the ability to walk safely in the real environment. Since a legged robot can be unstable while walking fast, one of the essential research topics is to reduce the contact impact force that is created between the foot and the surface during walking.

So far several approaches have been established to reduce impact/contact force, which is created from the ground surface.

By using heuristic approach, a method has been introduced by Huang [11] and Silva [12] to shift the foot position once it reaches the surface. However, there are problems in changing the foot position and PID coefficients voluntarily. Several researchers have studied the hybrid impedance and computed torque control, and the hybrid position and force control for the impedance adjustment of the leg [13][14]. However in this situation, the complex dynamics of the robot must be known, besides it being difficult to find control parameters. In addition to these, there is a study which tries to decrease the force using special foot structure [15].

This paper propose a method to reduce the landing impact force of a humanoid robot. Time domain passivity approach [16][17] is implemented for this purpose. The robot's foot is modeled as a one-port network system with admittance causality (the landing impact force is an input, and foot's position is an output). By calculating the energy input into the one-port network based on the landing force and the foot position, the foot of the robot is controlled to be passive. Unlike previous works, the proposed control method can guarantee the stable dynamic walking without any model information, and requires very little additional computation.

In this paper, the novel foot mechanism which uses four FSRs (Force Sensing Resistors on each foot) is introduced as well for measuring the landing force efficiently. Force torque (F/T) sensor has been generally used to measure the force that is applied to the foot due to the good accuracy. However, the F/T sensor usually has relatively large volume and heavy weight. Therefore, a small-sized humanoid robot mainly uses FSR sensors. They are usually attached to the sole of the foot, while the F/T sensor is usually attached to the ankle of the robot. Thus, when we use FSR sensors, the accuracy of the sensor system depends on the structure of the sole of the foot. In this paper, a new foot structure is proposed. It contains four FSR sensors on the sole of the foot that are independently movable and perceiving the force accurately.

The small-sized humanoid robot, HanSaRam-VI, which has 25 DOFs and uses the proposed foot mechanism, is developed

to verify the passivity control. The validity of the proposed control method is confirmed through dynamic walking experiments.

The remainder of this paper is organized as follows: Section II describes passivity concept and modeling of robot's foot system. Section III proposes the time domain passivity controller for reducing the landing impact force. The novel foot structure for efficient sensing force is presented in Section IV. Section V presents the experimental results with the proposed controller. Finally, conclusions follow in Section VI.

II. PASSIVITY AND SYSTEM MODELING

In this section, we briefly review the passivity of a sampled time system, and model the robot's foot and the ground in terms of network sense.

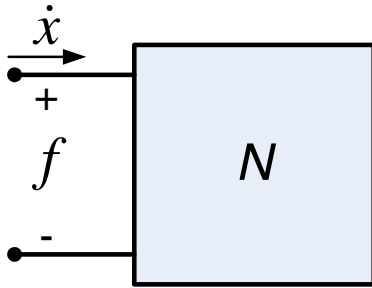

Fig. 1. One-port network model.

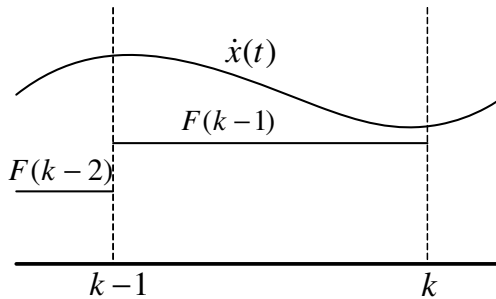

Fig. 2. Sampled time notation.

A. Passivity in Sampled Time System

First, we define the sign convention for all forces and velocities, so that their product is positive when power enters the system port. Also, the system is assumed to have initial stored energy at $t = 0$ of $E(0)$ (Fig. 1).

Several variables are defined for the sampled time system during one sample time (Fig. 2).

- 1) $f(t) = F(k-1)$ is the force, which is assumed to be constant.
- 2) $\dot{x}(t)$ is the system velocity.
- 3) $x(k)$ and $x(k-1)$ are the position at k and $k-1$ sample times, respectively.

The following widely known definition of passivity is then used [18].

Definition 1: The one-port network N with initial energy storage $E(0)$ is sampled time passive if and only if

$$E(k) = \sum_{j=0}^k F(j-1)(x(j) - x(j-1)) + E(0) \geq 0 \quad (1)$$

where $k = 0, 1, 2, \dots$, for sampled force $F(j)$ and position $x(j)$. If $E(k) \geq 0$ for every k , this means the system dissipates energy. If there is an instance that $E(k) < 0$, this means the system generates energy, and the amount of generated energy is $-E(k)$.

B. Robot's foot system modeling

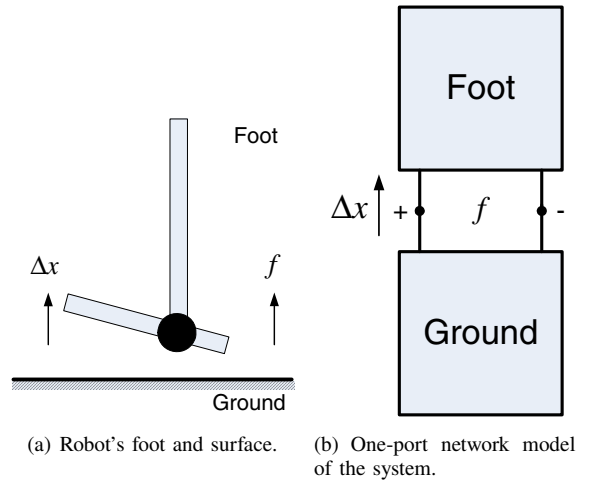

Fig. 3. Robot's foot system modeling.

To implement the time domain passivity approach, the robot's foot and the ground are modeled as a network system. Both systems can be modeled as one-port network systems, which are connected to each other. The impedance of the ground is zero when the foot is in swing mode, and has a certain value when the foot is in contact with ground. Fig. 3 shows the real and the modeled network system, respectively. The sign convention for force and velocity is defined so that the energy is positive when the power enters the system port of the robot's foot. In fig. 3(b), the force and the velocity are positive in the upper direction.

Since the ground can be considered as an intrinsically passive system, the connected system (the robot's foot and the ground) can be passive if only the robot's foot, one port network, is passive. Once we prove the passivity, stability of the robot system can be guaranteed because passivity is a sufficient condition of stability. This is a situation where the foot is physically absorbing the contact force and showing the motion of sitting down.

On the other hand, when the robot's foot, one port network, is active (while the input energy is negative), the robot might be unstable. This is the case when the robot's foot kicks the surface, it causes a big landing impact force between the foot and the ground. This force is the main reason for the

unstable walking. Therefore, a control algorithm is required for reducing the big landing impact force.

III. COMPENSATION FOR THE LANDING IMPACT FORCE USING TIME DOMAIN PASSIVITY CONTROL

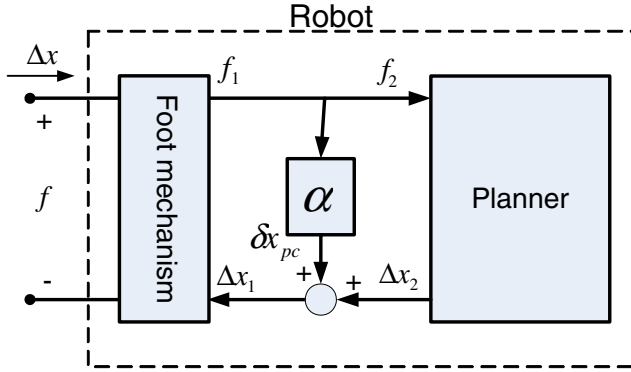

Fig. 4. One-port network with PO/PC.

We can divide the one-port network of the robot's foot system into two parts, mechanism part with low-level position controller and planner part with high-level controller. Fig. 4 shows the separated network system of robot's foot. $f (= f_1 = f_2)$ is the landing impact force, which can be measured by the FSR sensors on the robot's foot. x is the actual height position of the robot's foot, and Δx is the difference between two consecutive sampled data of x . The modified position x_1 is obtained from the originally planned trajectory (x_2) and the output of the passivity controller (δx_{pc}). x_2 is a planned height position of walking trajectory from the planner, which did not consider the landing impact force from the ground. If we use the originally planned walking trajectory, the robot's foot might get a big landing impact force from the ground in a very short time, and it makes the one-port of the robot's foot active. For reducing the landing impact force, the passivity controller is attached to modify the original walking trajectory (x_2) to x_1 by adding δx_{pc} . Therefore, the robot takes the ground reaction force into account and it can make a contact with the ground more securely.

The proposed time-domain passivity control system consists of a passivity controller (PC) and passivity observer (PO), which controls and monitors the input/output energy flow between the robot's foot and the ground. Passivity observer computes the energy flow using the landing force and the foot position as follows:

$$W(k) = W(k-1) + f_1(k-1)(x_1(k) - x_1(k-1)) \quad (2)$$

$$W_o(k+1) = W(k) + f_1(k)(x_2(k+1) - x_1(k)) \quad (3)$$

where $W(k)$ is the total energy output from 0 to k , and $W_o(k+1)$ is the prediction of the one-step-ahead energy output. The last term of Eq. (3) is the estimation of the one-step-ahead energy output, which is the output energy from k to $k+1$. Note that we know the planned position $x_2(k+1)$ at step k .

If the PO can predict whether the system at the next step will be passive or not at the current step k , the PC can modify the desired position at the next step ($k+1$) to make the system passive. The PC absorbs exactly the net energy output (if any) measured by the passivity observer at each time sample.

Based on the PO and steps 4 and 5 below, the PC algorithm (steps 6 and 7 below) for the one-port robot's foot with admittance causality is developed as follows:

- 1) $f_1(k) = f_2(k)$ is the input;
- 2) $\Delta x_1(k) = x_1(k) - x_1(k-1)$
 $\Delta x_2(k+1) = x_2(k+1) - x_1(k)$;
- 3) $\Delta x_2(k)$ is the output of the one-port network;
- 4) $W(k) = W(k-1) + f_1(k-1)\Delta x_1(k)$ is the energy output at step k
- 5) $W_c(k+1) = W(k) + f_1(k)\Delta x_2(k+1)$ is the prediction of the energy level at step $k+1$
- 6) The PC output for making the system passive is calculated as follows:

$$\delta x_{pc} = \begin{cases} -\frac{W_c(k+1)}{f_1(k)}, & \text{if } W_c(k+1) < 0 \\ 0, & \text{if } W_c(k+1) \geq 0 \end{cases}$$

- 7) The modified desired height position can be calculated from $\Delta x_1(k+1) = \Delta x_2(k+1) + \delta x_{pc}(k)$.

Please note that the PO/PC is for achieving the stable landing of humanoid robot. Once the stable landing is achieved (maintaining N steps with positive energy, and N is constant.), the robot's walking path should be modified to follow the initially planned walking path. The walking pattern, changed by the passivity controller, is interpolated to the initially planned walking trajectory by using the polynomial method. In this stage, passivity observer is also reset to prepare the next observation.

IV. FOOT MECHANISM FOR FORCE MEASUREMENT

In a design aspect, the proposed foot structure, as shown in Fig. 5, is unique when it is compared to other humanoid robots [19]. The FSR sensors are added to the end-tip sensor stages (Fig. 5(b)). If a foot hits the ground, the tip point of a ball joint will push sensors through a round shaped flat panel. This sensing mechanism can measure not only perpendicular contact force, but also diagonal ground contact force. Since the end-tip sensor can rotate toward the ground according to the movement of foot plate, the sensor stages enable the FSRs to measure the landing impact force or the ground reaction force even though the foot hits the ground in non-perpendicular direction.

Moreover, the sequence of the landing of each four FSRs can be known because each sensor stage is independently connected to the foot plate.

V. EXPERIMENTS

In this section, the proposed time-domain passivity control approach is verified through real experiments with a small-sized humanoid robot platform.



(a) Foot structure with four FSRs.

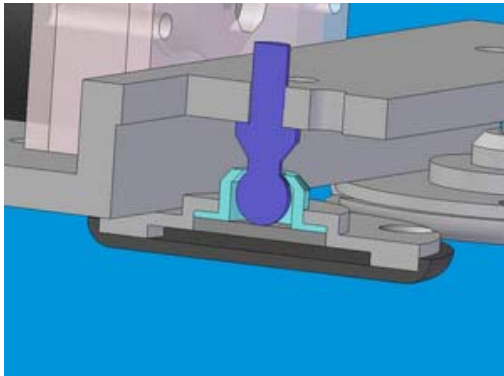

(b) End-tip sensor stage.

Fig. 5. Foot structure for force measurement.

A. System Description

Fig. 6 shows small-sized humanoid robot, HanSaRam-VI. It has 25 DOFs, and consists of 12 DC motors in lower body and 13 RC servo motors in upper body. Its height and weight are 52 cm and 4.5 kg, respectively. This biped robot's structure is mainly composed of Duralumin. Even though HanSaRam-VI is a small humanoid robot, the design of the lower body is focused on generating sufficient power and accurate control, and consists of DC motors and Harmonic drives. In the design of the upper body, 13 RC servo motors are used, since RC servo is light in weight and easy to control.

The on-board Pentium-III compatible PC, running RT-Linux, calculates the walking pattern in real time. The walking pattern is generated on-line through three-dimensional inverted pendulum mode [20]. The stand-alone vision system using PDA is equipped to find out three colors in real time. To measure forces on the foot, 4 FSRs with the proposed foot mechanism are equipped on each foot.

With the help of all the computational and power parts, HanSaRam-VI has the ability for fully independent locomotion, sensing, and processing.



Fig. 6. HanSaRam-VI.

B. Experimental Results

Dynamic walking experiments were performed to verify the proposed time-domain passivity control approach. The results are compared with those without PO/PC. In the experiments, the biped robot walked with a speed of 4 cm/s and a step length of 3 cm. Double and single support phases of a step were 0.15 s and 0.6 s, respectively. All experimental results are plotted after the initial 2 seconds of operation and then for 5 seconds thereafter.

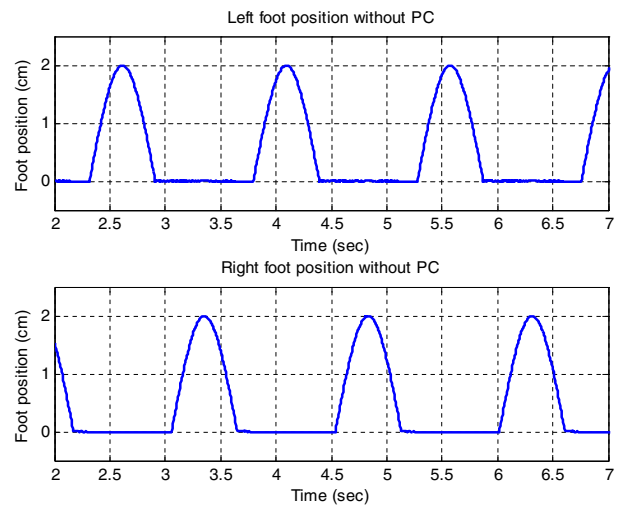

Fig. 7. Foot's height position without PO/PC.

First, the experiments were performed without PO/PC. Fig. 7 shows the walking trajectory without considering landing impact force. When robot's foot was landing, there was a big landing force as shown in Fig. 8. This force caused 'double contacts' of the foot. Even after the robot's foot was landed on the ground, it was bounced back from the ground instantaneously due to the big landing force such that it disturbed stable dynamic walking. It should be noted that two force plots are different because the mass distribution was

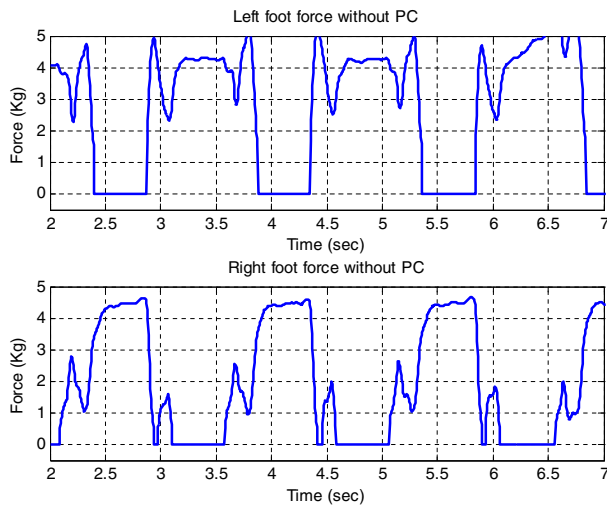

Fig. 8. Force without PO/PC.

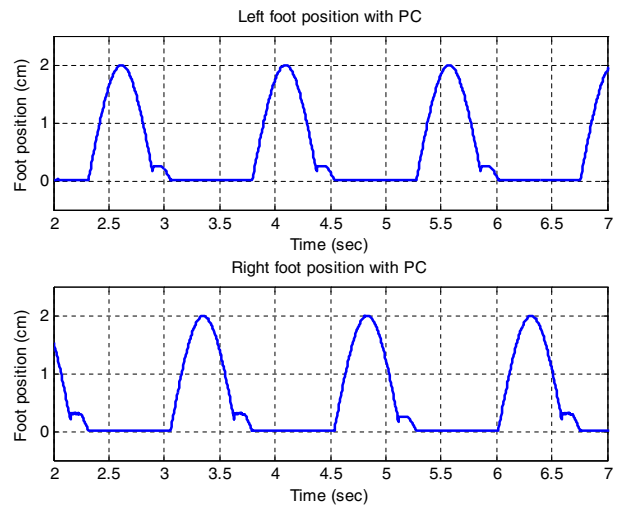

Fig. 10. Foot's height position with PO/PC.

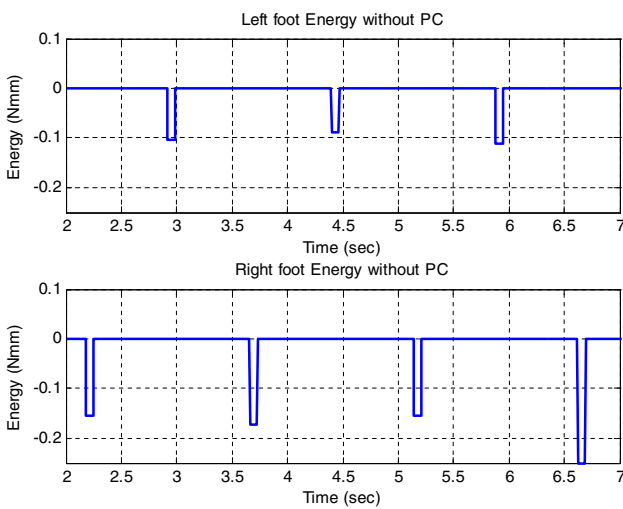

Fig. 9. Energy without PO/PC.

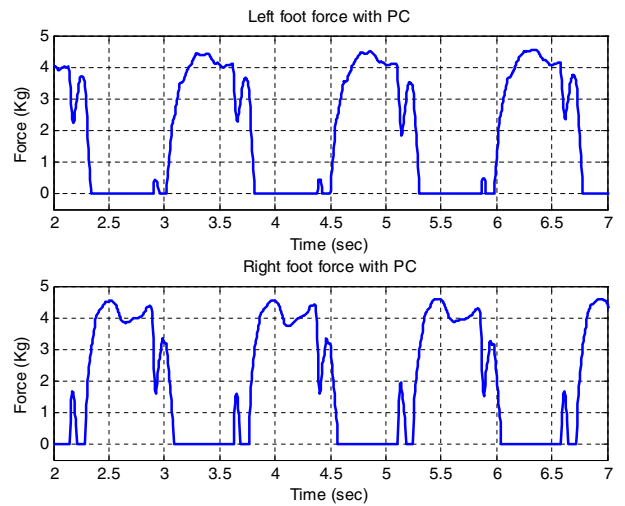

Fig. 11. Force with PO/PC.

asymmetry in the real robot. Fig. 9 shows the input energy from the one-port robot's foot. When the foot kicks the surface, the energy becomes negative, and the robot's foot is no longer passive. It means that the robot might be unstable due to this active energy output from the foot.

Fig. 10 - Fig. 12 show the results when the proposed time-domain passivity approach implemented. The modified walking trajectory is plotted in Fig. 10. Foot is slightly moved upward on each landing time, since the passivity controller modified the desired foot trajectory to satisfy the passivity condition. After 10 steps in which the energy stays positive, it was shifted to its original position by cubic spline interpolation. As shown in Fig. 11, the impact force was reduced, because the passivity controller immediately reduced the impact force. There was no 'double contact' any more. Fig. 12 shows that energy was also positive with the passivity control. It means

that the robot system does not give off the active energy which could make the system unstable.

The results of the overall experiments indicate that the proposed passivity controller decreases the impulsive landing impact force at the ground surface and makes stable foot landings possible. It is important to remember that system dynamic equations are not used any more in the proposed method. Moreover, control parameters are not required.

VI. CONCLUSION

This paper proposed a new method to compensate for the landing impact force or the ground reaction force of a humanoid robot. For the use of the time-domain passivity approach, the ground and the robot's foot were modeled as two one-port network systems, which were connected and exchanging energy each other. Admittance type time-domain passivity controller, which has the landing impact force as

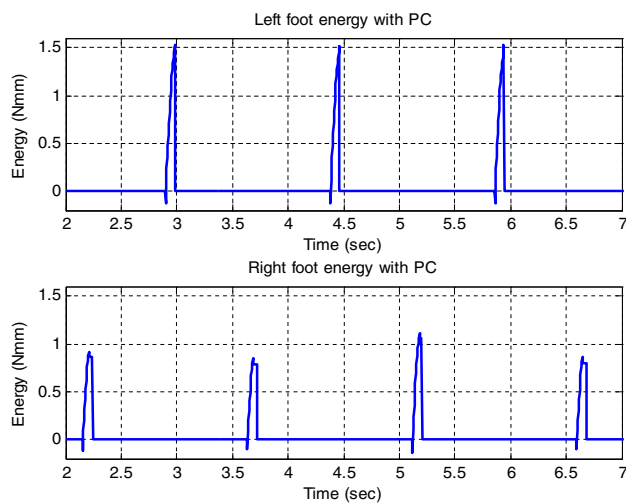

Fig. 12. Energy with PO/PC.

an input and foot's height position as an output, was implemented. The proposed controller could guarantee the stable dynamic walking without any system model information at all. In this paper, the novel foot mechanism which used FSRs (Force Sensing Resistors) was also introduced for measuring landing impact force efficiently. The proposed time-domain passivity controller was verified with the developed small-sized humanoid robot, HanSaRam-VI. The proposed control method could stabilize the landing motion of the biped robot.

ACKNOWLEDGMENT

This work was supported by the Ministry of information & Communications, Korea, under the Information Technology Research Center (ITRC) Support Program.

REFERENCES

- [1] K. Hirai, M. Hirose, Y. Haikawa, and T. Takenaka, "The development of honda humanoid robot," in *Proc. of IEEE Int. Conf. on Robotics and Automations*, Leuven, Belgium, May 1998, pp. 1321–1326.
- [2] J. Yamaguchi, A. Takanishi, and I. Kato, "Development of a biped walking robot compensating for three-axis moment by trunk motion," in *Proc. of IEEE/RSJ Int. Conf. on Intelligent Robots and Systems*, vol. 1, Yokohama, Japan, July 1993, pp. 561–566.
- [3] K. Nishiwaki, T. Sugihara, S. Kagami, F. Sanehiro, and M. Inaba, "Design and development of research platform for perception-action integration in humanoid robot: H6," in *Proc. of IEEE/RSJ Int. Conf. on Intelligent Robots and Systems*, vol. 3, Takamatus, Japan, Oct. 2000, pp. 1559–1564.
- [4] J.-H. Kim, D.-H. Kim, Y.-J. Kim, K.-H. Park, J.-H. Park, C.-K. Moon, K. T. Seow, and K.-C. Koh, "Humanoid robot hansaram: Recent progress and development," *J. of Advanced Computational Intelligence & Intelligent Informatics*, vol. 8, no. 1, pp. 45–55, Jan. 2004.
- [5] S. Setiawan, S. Hyon, J. Yamaguchi, and A. Takanish, "Physical interaction between human and a bipedal humanoid robot," in *Proc. of IEEE Int. Conf. on Robotics and Automation*, vol. 1, Detroit, MI, May 1999, pp. 361–367.
- [6] K. Harada, S. Kajita, F. Kanehiro, K. Fujiwara, K. Kaneko, K. Yokoi, and H. Hirukawa, "Real-time planning of humanoid robot's gait for force controlled manipulation," in *Proc. of IEEE Int. Conf. on Robotics and Automation*, vol. 1, New Orleans, LA, Apr. 2004, pp. 616–622.
- [7] S. Kajita, A. Kobayashi, and T. Yamamura, "Dynamic walking control of a biped robot along a potential energy conserving orbit," *IEEE Trans. on Robotics and Automation*, vol. 8, pp. 431–438, Aug. 1992.

- [8] Q. Huang, K. Yokoi, S. Kajit, K. Kaneko, H. Arai, N. Koyachi, and K. Tanie, "Planning walking patterns for a biped robot," *IEEE Trans. on Robotics and Automation*, vol. 17, no. 3, pp. 280–289, June 2001.
- [9] J. Yamaguchi, E. Soga, S. Inoue, , and A. Takanishi, "Development of a bipedal humanoid robot control method of whole body cooperative dynamic biped walking," in *Proc. of IEEE Int. Conf. on Robotics and Automation*, vol. 1, Detroit, MI, May 1999, pp. 368–374.
- [10] B.-J. Lee, Y.-D. Kim, and J.-H. Kim, "Balance control of humanoid robot for hurosot," in *Proc. of IFAC World Congress*, Prague, Czech, July 2005.
- [11] Q. Huang, K. Kaneko, K. Yokoi, S. Kajita, T. Kotoku, N. Koyachi, H. Arai, N. Imamura, K. Komoriya, and K. Tanie, "Balance control of a biped robot combining off-line pattern with real-time modification," in *Proc. of IEEE Int. Conf. on Robotics and Automation*, vol. 4, San Francisco, CA, Apr. 2000, pp. 3346–3352.
- [12] F. Silva and J. Machado, "Position/force control of biped walking robots," in *Proc. of IEEE Int. Conf. on System, Man, and Cybernetics*, vol. 5, Nashville, TN, Oct. 2000, pp. 3288–3293.
- [13] J.-H. Park, "Impedance control for biped robot locomotion," *IEEE Trans. on Robotics and Automation*, vol. 17, no. 6, pp. 870–882, Dec. 2001.
- [14] H.-O. Lim, S. Setiawan, and A. Takanishi, "Position-based impedance control of a biped humanoid robot," *Advanced Robotics*, vol. 18, no. 4, pp. 415–435, 2004.
- [15] J. Yamaguchi, A. Takanishi, and I. Kato, "Experimental development of a foot mechanism with shock absorbing material for acquisition of landing surface position information and stabilization of dynamic biped walking," in *Proc. of IEEE Int. Conf. on Robotics and Automation*, vol. 3, Nagoya, Japan, May 1995, pp. 2892–2899.
- [16] B. Hannaford and J.-H. Ryu, "Time-domain passivity control of haptic interfaces," *IEEE Trans. on Robotics and Automation*, vol. 18, pp. 1–10, Feb. 2002.
- [17] J.-H. Ryu, D.-S. Kwon, and B. Hannaford, "Stability guaranteed control: time domain passivity approach," *IEEE Trans. on Control Systems Technology*, vol. 12, pp. 860–868, Nov. 2004.
- [18] J.-H. Ryu, Y.-S. Kim, and B. Hannaford, "Sampled- and continuous-time passivity and stability of virtual environments," *IEEE Trans. on Robotics*, vol. 20, no. 4, pp. 772–776, Aug. 2004.
- [19] K. Erbatu, A. Okazaki, T. Takahashi, and A. Kawamura, "A study on the zero moment point measurement for biped walking robots," in *Proc. of IEEE Int. Workshop on Advanced Motion Control*, Maribor, Slovenia, July 2002, pp. 431–436.
- [20] S. Kajita, F. Kanehiro, K. Kaneko, K. Fujiwara, K. Yokoi, and H. Hirukawa, "Biped walking pattern generation by a simple three-dimensional inverted pendulum model," *Advanced Robotics*, vol. 17, no. 2, pp. 131–147, 2003.